

FEATURES

- Multi-range input T/C, RTD, mV, V, mA, POT, Etc
- Display off function (Power saving)
- High accuracy 16bit A/D converter
- Peak hold function (Highest & Lowest)
- RS-485 Communication interface
- 2points alarm & Dead band set
- Display input error
- Burnout function (Output High/Low selection)
- Sensor power source DC 24V in STD specification
- Free voltage (AC 85~265V, 45~65Hz)
- Isolation current output & Output scaling



30(W) X 62(H) X 60(D)

SPECIFICATIONS

- ▶ **Measuring and display cycle :**
200ms(mV, Volt, mA type)
400ms(TC, RTD type)
- ▶ **Input resistance :** Volt-400k Ω
Others type-1M Ω
- ▶ **Signal source resistance :** Pt 100 Ω type-30 Ω /line
Others type-300 Ω /line
- ▶ **CMRR(Common Mode Rejection Ratio) :** 140dB or more
- ▶ **NMRR(Normal Mode Rejection Ratio) :** 60dB or more
- ▶ **Moving average filter**
- ▶ **Built-in sensor power source :** DC 24V 30mA \pm 0.5%
- ▶ **Accuracy :** \pm 0.2% FS
- ▶ **Isolation current output**
(2 output is isolation between output)
Current : DC 4.00~20.00mA
Maximum load resistance : 600 Ω
Isolation resistance(Input-Output) : 100M Ω or more
(DC 500V)
- ▶ **Isolation voltage output(Option)**
Voltage : DC 0~10V
Minimum load resistance : 1k Ω
Isolation resistance(Input-Output) : 100M Ω or more
(DC 500V)
- ▶ **Alarm output(Alarm setter)**
Contact output type : Normal open, Normal close
Max switching power : 60W 125VA
Max switching voltage : DC 220V, AC 250V
Max switching current : DC 2A, AC
Max Carrying current : DC 3A, AC
- ▶ **Ambient temperature & Humidity**
Operation : -20~60 $^{\circ}$ C, 10~90%
Storage : -20~60 $^{\circ}$ C, 10~90%
- ▶ **Power supply**
Voltage : AC 85~265V(45~65Hz)
DC 24V(Option)
Power consumption : Max 4VA
Isolation resistance : 100M Ω , DC 500V
(FG-Input, FG-Power, Power-Input, Input-Output)
- ▶ **Etc**
Weight : 130g
Mounting : Din rail & wall mounted
Dimension : 30(W) x 62(H) x 60(D)mm

PARTS NAME

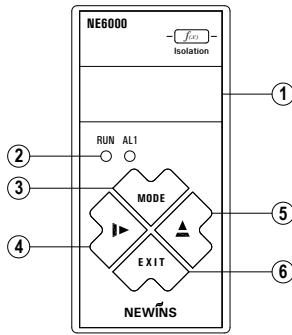

- ① Measured value display
- ② Communication lamp
- ③ **MODE** Key :
Storage the set data and change the operation menu
- ④ **←** Key :
Enter into the data setting mode and modify the changed location
- ⑤ **↑** Key :
Change the data value
- ⑥ **EXIT** Key :
Out of mode

INPUT TYPE

Sensor Type	Range	Scale	Symbol	
TC	B(PR)	0 ~ 1800°C	-	EE-b
	R(PR)	0 ~ 1750°C	-	EE-r
	S(PR)	0 ~ 1750°C	-	EE-S
	K(CA)	-200 ~ 1350°C	-	EE-E
	E(CRC)	-199.9 ~ 700.0°C	-	EE-E
	J(IC)	-199.9 ~ 800.0°C	-	EE-J
T(CC)	-199.9 ~ 400.0°C	-	EE-t	
Volt	mV	-50.0 ~ 50.0mV	-1999 ~ 9999	~u
	Volt	-1.000 ~ 1.000V	-1999 ~ 9999	!u
	Volt	-10.0 ~ 10.0V	-1999 ~ 9999	!0u
mA	mA	4.00 ~ 20.00mA	-1999 ~ 9999	~R
PT	Pt100Ω	-199.9 ~ 800.0°C	-	d-Pt
	JPt100Ω	-199.9 ~ 500.0°C	-	J-Pt
POT	Potention meter 1k	0 ~ 1KΩ(2kΩ)	-1999 ~ 9999	Po 1t
	Potention meter 5k	0 ~ 5KΩ(10kΩ)	-1999 ~ 9999	Po 5t

* mA input needs 250Ω(±0.1% 25ppm) resistance spiral on outside

MAJOR FUNCTIONS

▶ Power-saving function

EE~E

If set to ON, FND disappears after 30 minutes, and LED will be blink.

▶ Error message display function

- HHou** High Range over
- LLou** Low Range over
- ErR1** RTD "A" open
- ErR2** RTD "B" open, TC input open
- ErR3** RTD "b" open
- ErE** CJC error

▶ Display scaling function(mV, Volt, mA only)

This function changes and sets the display value according to scale and input range.

Ex) In case of input range 4.00 ~ 20.00mA and Level 0.00 ~ 7.00m

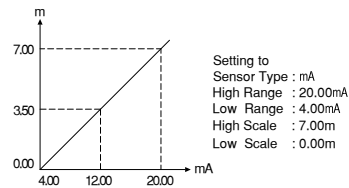

▶ Output scaling function

This function can change the 4.00 ~ 20.00mA value as the output scale.

Ex) In case of display value 0.00 ~ 7.00m, Output 4.00 ~ 20.00mA

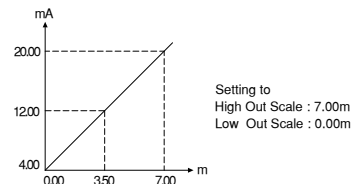

▶ Function(mV, Volt, mA type)

L in

Pass the input as it is.

Used for general input type and linearity input.

root

Pass the input after √. Used for flow rate by orifice.

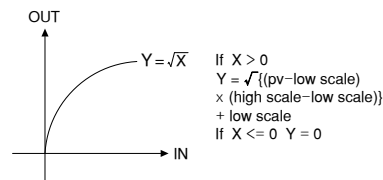

L inE

Like level measuring, when it does not display measuring under zero, it always can display zero by using limit function.

► Filter Function

Filter number can select to 10~70. Filter is average for data excluded from a max/min value during a selected number of input data received.

► Sensor compensation function

The function is useful for compensating error by long sensor line or changed zero point by aged sensor.

Ex) Before sensor adjust = 510℃
 After = measured value + compensated value
 = 510 - 10
 = 500℃

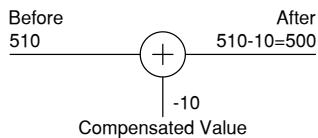

► Peak hold function

- Peak mode 0** High peak mode
Remember the highest input value and display the highest value when pressing the key.
- Peak mode 1** Low peak mode
Remember the lowest input value and display the lowest value when pressing the key.
- Peak mode 2** High peak & Display mode
Remember the highest input value, display the highest value in ordinary times, and output the highest transmit output.
- Peak mode 3** Low peak & Display mode
Remember the lowest input value, display the lowest value in ordinary times, and output the lowest transmit output.

► Analog output Function

If input sensor is opened, analog output is outputed to max/min value.
 High : 20.000mA , Low : 4.000mA

► Alarm function

Alarm type : High, Low, Middle.
 The alarm consists of 2 relays, and it can output relay contact output individually
 Ex) AL-1 : High alarm value 500.0,
 AL-2 : Low alarm value 100.0,
 AL-3 : Middle alarm value 500.0
 Alarm dead band setting 0.5
 The high alarm(AL-1) is ON when the present value(PV) is 500.0 or more, and OFF when 499.5 or less. The low alarm(AL-2) is OFF when the present value(PV) is 100.5 or more, and ON when 100.0 or less.

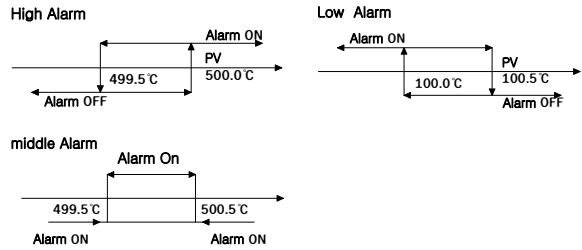

► Communication interface

It is possible to communicate with computer and to monitor remote by using RS-485 communication interface.

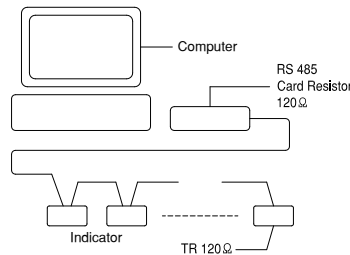

ORDERING CODE

NE60		-	Description
Analog output	00		DC 4.00~20.00mA
	01		DC 4.00~20.00mA (2 Out)
	02		1~5 Volt
	03		1~5 Volt(2 Out)
	04		0~10 Volt
	05		0~10 Volt (2 Out)
	06		4.00~20.00mA + 1 Alarm
	07		1~5 Volt + 1 Alarm
	08		4.00~20.00mA + RS 485(RTU)
	09		1~5 Volt + RS 485(RTU)
	10		4.00~20.00mA + 1 Alarm + RS485(RTU)
	11		1~5 Volt + 1 Alarm + RS 485(RTU)
	12		Etc
Power	0		AC 85~265V(45~65Hz)
	1		DC 12~32V
	2		Etc

TERMINAL DIAGRAM

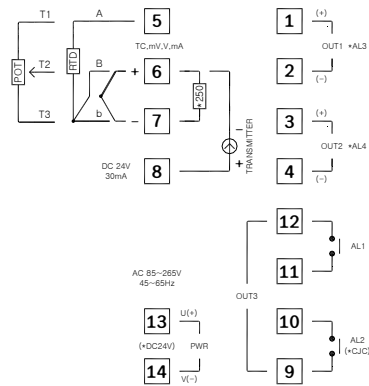

*NOTE
 1.mA Input (+,-)Needs 250 OHM 0.05% 25ppm Resistance
 2.*TC-TYPE CJC ONLY(AL2 NONE)

DIMENSION

► Single Mounting (unit:mm)

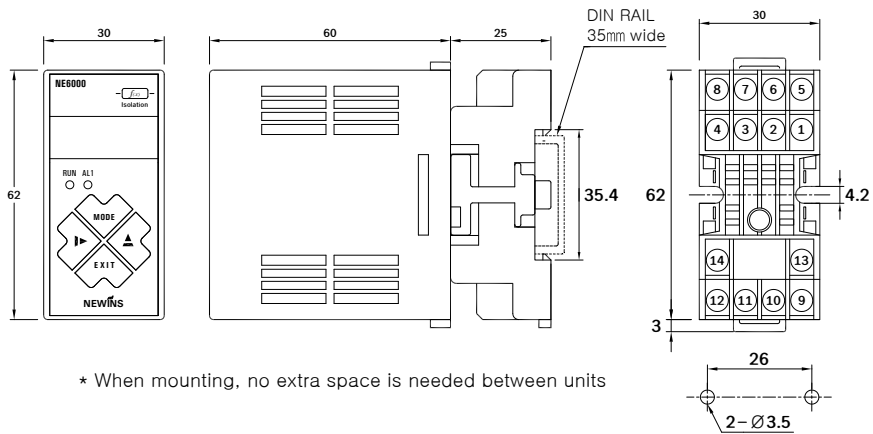

* When mounting, no extra space is needed between units

► Multi Mounting (unit:mm)

※ To avoid a shock between the home and the home oh the socket, insert the adhesion

